

The user should read this manual thoroughly before operation and observe the method and precautions for more effective operation.

POWER TAKE OFF

INSTRUCTION MANUAL

MODEL : DPO 210,310S(P)

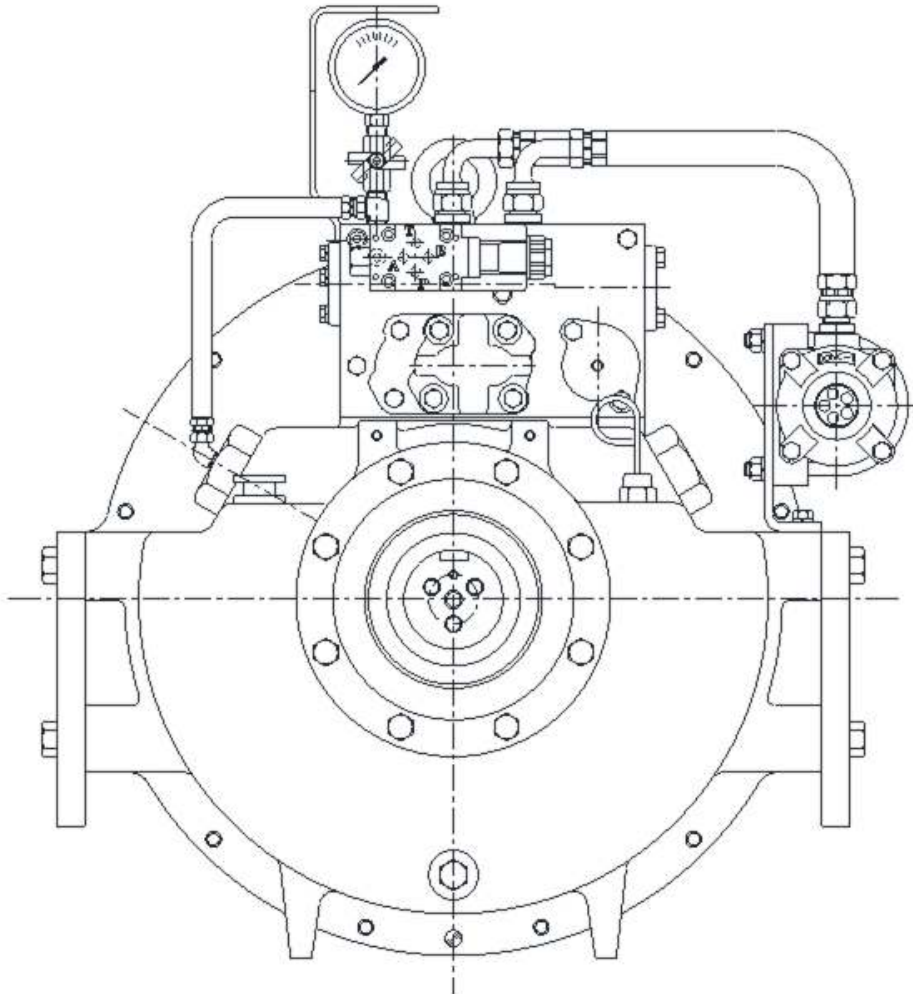

© D-I INDUSTRIAL CO., LTD.

APPRECIATION

Appreciate you prefer to use our PTO. D-I PTO was made under the scientific research and design, hi-technology and thorough quality control to get the customer's reliability. In case of inconvenient things and further requirements while you use the PTO, you are kindly required to contact to our agent or head office.



TIP TO RECEIVE THE WARRANTY SERVICE

1. You shall sign on the receipt of PTO delivery when you receive the new PTO.
2. After installation of PTO, contact the A/S department of head office to get the periodical check.
3. In case of the abnormal condition under the warranty period, contact our agent or A/S department in head office and present the warranty letter of this manual. If the third party D-I doesn't admit maintains the PTO, you cannot get any warranty benefit.



INTRODUCTION

This manual contains description of construction, operating principles, correct operation and handling methods, precautions for installation, information on repair and check, etc. for D-I P.T.O

APPLICATION	POWER TAKE OFF (P.T.O)
MODEL	DPO-210,310S(P)
The users should read this manual thoroughly before operation and observe the operating methods and precautions. Keep this manual at a safe place for future reference.	

Before operation, users should read the contents  marked in this manual. Since the contents  marked are very important for safety, users should follow the instructions.

In this manual, danger degrees, which can be occurred by faulty use, are shown in the following table.

 DANGER	Failure to observe these items could result in severe injure or death.
 CAUTION	Failure to observe these items could result in severe injure or death. Mechanical damage can also occur.
 IMPORTANT	Failure to observe these items could result in mechanical damage.

CONTENTS

SECTION 1	INTRODUCTION
SECTION 2	CONSTRUCTION
SECTION 3	PRINCIPLES OF OPERATION
SECTION 4	HYDRAULIC SYSTEM
SECTION 5	INSTALLATION
SECTION 6	OPERATION
SECTION 7	PREVENTIVE MAINTENANCE
SECTION 8	TROUBLE SHOOTING
ANNEX I	PERIODIC INSPECTION TABLE
ANNEX II	PARTS ORDER SHEET
ANNEX III	WARRANTY LETTER

SECTION 1 – INTRODUCTION

1-1. MAJOR FUNCTIONS

The D-I Power Take Off (Hereunder PTO) described in this manual is a product to take power off an engine for the purpose of operating Hydraulic pumps, Winches or Generators etc.

The major functions supply one pulley which is always operating and one output shaft which we can operate when it is necessary. It is possible to use various applications as below and transmit the power into output shaft in the same rotating direction as engine's.

The power for operation of PTO is transmitted by hydraulic multiple clutches and the necessary hydraulic system is built-in the PTO.

1-2. SPECIFICATION

[Table. 1-1]

MODEL	MIN. SPEED (rpm)	MAX. SPEED (rpm)	INPUT TORQUE (kgf-m)	PERATION PRESSURE (kgf/cm ²)	LUB. PRESSURE (kgf/cm ²)	DRY WEIGHT (kg)	FLOW OF COOLING WATER (l/min)
DPO-F(R)310S(P)	600	2300	300	MIN 16	0.1-5	250	40-60
DPO-F(R)310S(P)H							
DPO-F(R)210S(P)			200				
DPO-F(R)210S(P)H							

1-3. MODEL NAME DESCRIPTION

EX) DPO - F(R)310 S(P) _ H1,2

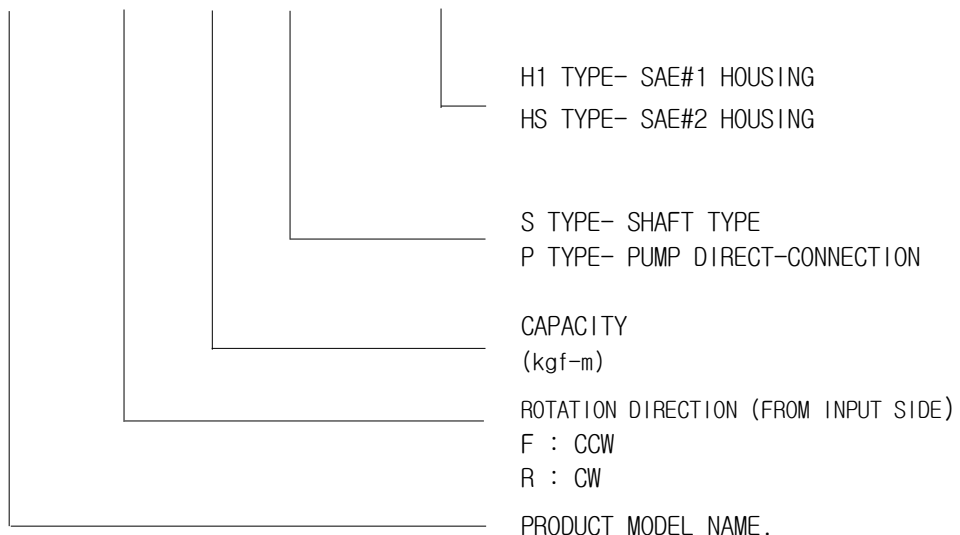

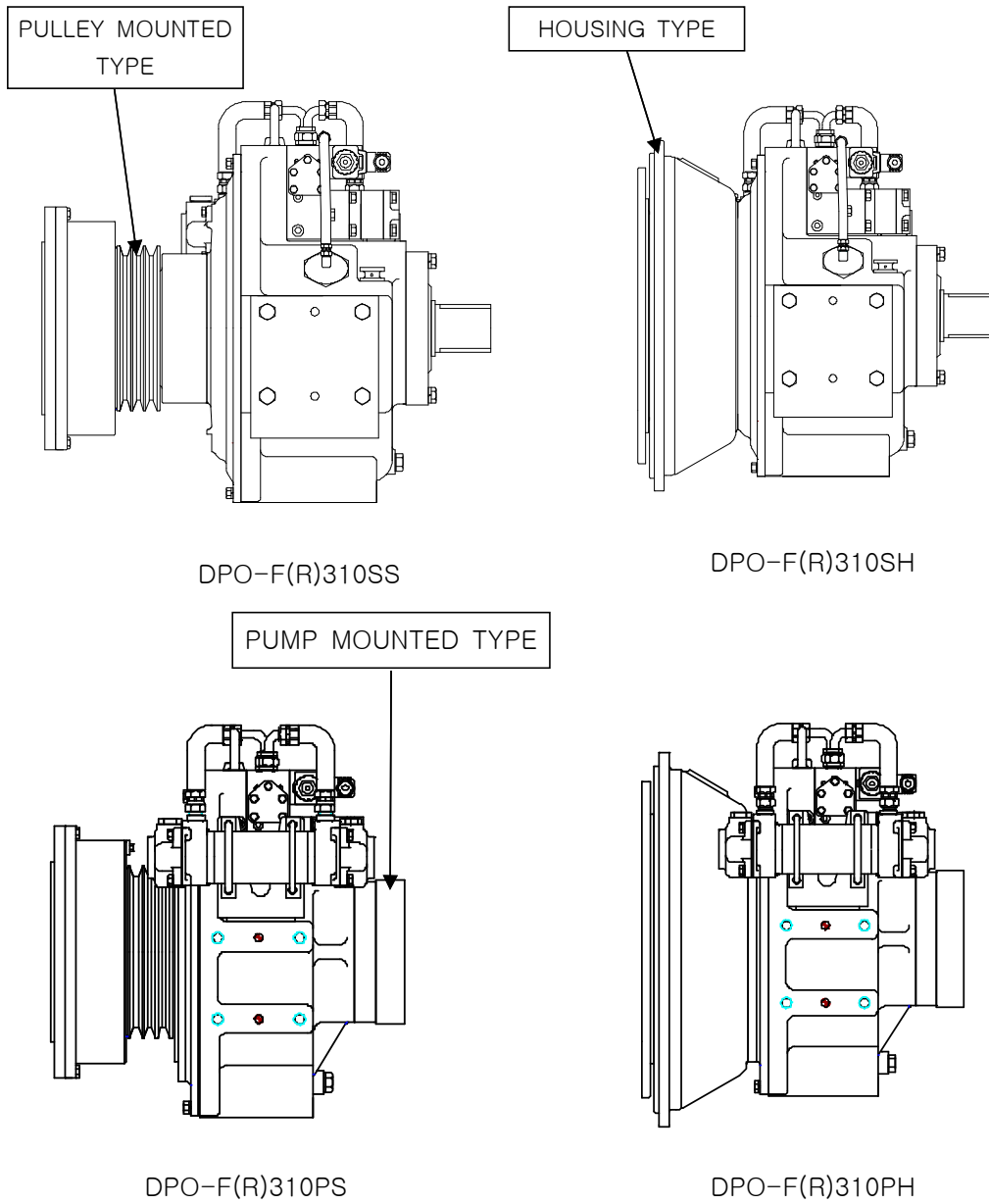

[FIG. 1-1] PTO SPECIFICATION

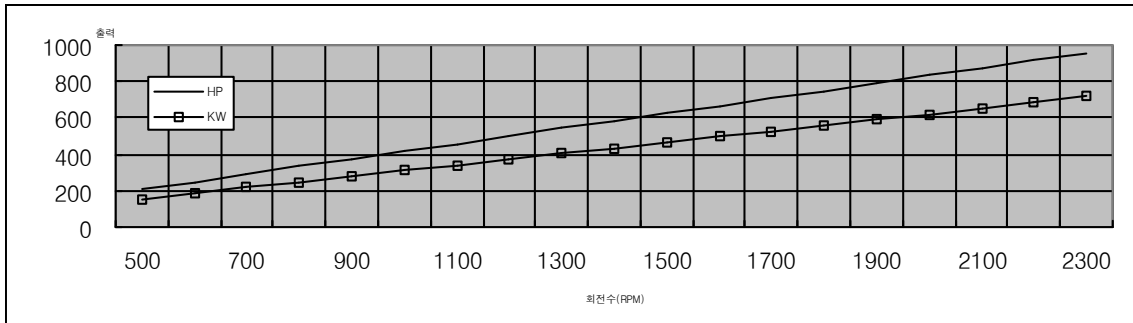

[FIG. 1-2] PTO - 310 PERFORMANCE CURVE

 **CAUTION**

D-I PTO must be operated within the limit of capacity of winch, roller, alternator or other equipment which PTO drives.

If not, slippage, overheating or breakage can occur.

Rotation direction is marked on the name plate with the model name. In case of the wrong rotation, out of operation and overheating can be occurred. (when stand to look at from input side, F: Counter Clock Wise , R: Clock Wise. As to the model name, refer to the MODEL NAME DESCRIPTION at 1-3). Please keep the using capacity and any query is required to contact our company.

SECTION 2 – CONSTRUCTION

2-1 GENERAL

D-I PTO can take power off an engine and it is a device to provide the convenience of work in the vessel and its main components are largely input shaft assembly and output shaft assembly.

Operation of PTO is performed by hydraulic clutch including oil pressure-producing pump assembly, oil cooler assembly, selector valve assembly and manifold assembly in the PTO for the hydraulic system. A brake system is equipped with this PTO to prevent the turning of output shaft with failure of stop.

Dummy plate is mounted with pulley of engine and then driving ring is coupled and through the spider and pulley, the power is transmitted into input shaft.

Or, engine and PTO's power is performed by flexible coupling.

Pulley(TYPE B, 3 LANES) equipped in the input shaft is always driving as per engine operation and output shaft assembly is operated by the hydraulic clutch.

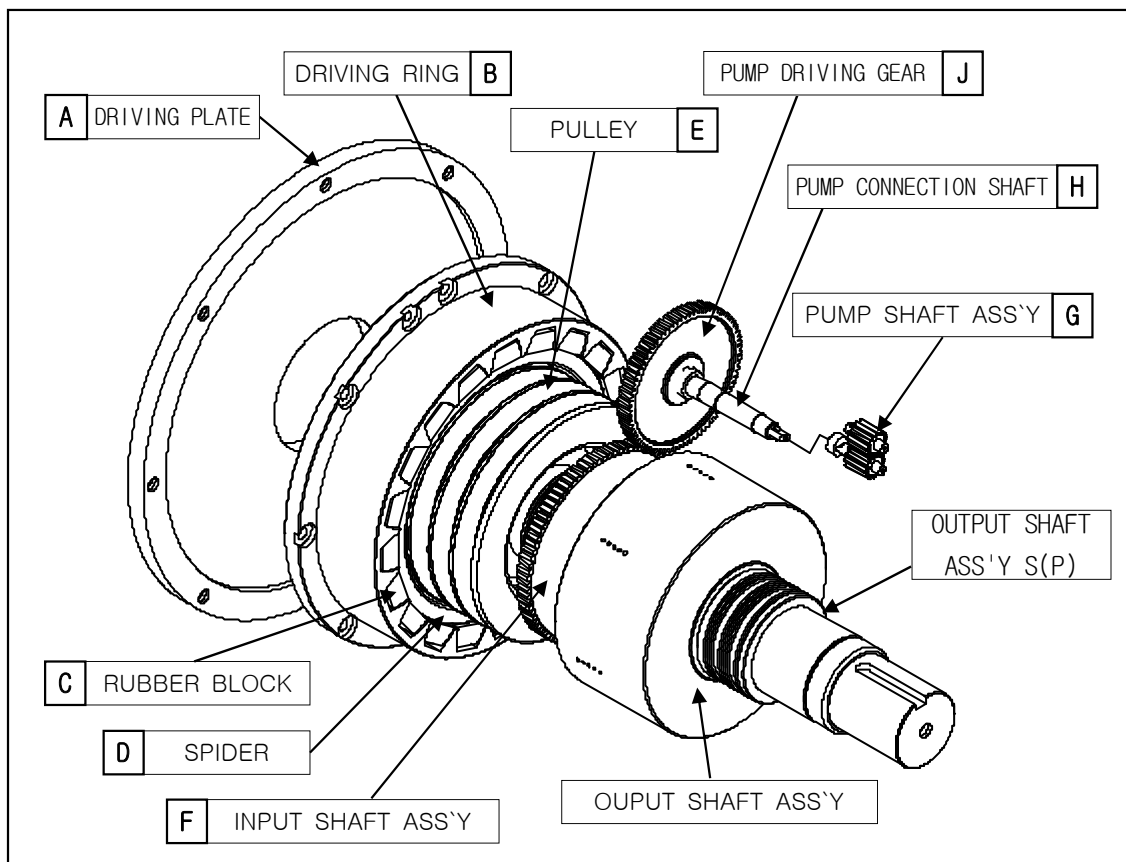

[FIG. 2-1] PTO INTERNAL STRUCTURE

2-2 INPUT SHAFT GROUP

1. Driving plate – (Fig. 2-1 A)

The driving plate supplied is to be fitted to the pulley of engine. In order to fit the driving plate to the engine pulley, the driving plate should be suitably machined for the pulley. The driving plate is to be bolted directly to the pulley of engine.

2. Driving Ring – (Fig. 2-1 B)

The driving ring is furnished with the involute grooves on which the rubber blocks are fixed to transmit power, and is bolted directly to the driving plate.

3. Rubber Block – (Fig. 2-1 C)

The rubber blocks are in the shape of involute gear teeth, and reduce rotative vibration of the engine and transmit the power smoothly.

4. Spider – (Fig. 2-1 D)

The spider is fixed on the pulley of PTO with fitted bolts, and constructed in a manner that the rubber block can be fixed on it.

5. Pulley – (Fig. 2-1 E)

The pulley on the PTO is V type double pulley, and fitted to Input shaft.

6. Input Coupling

The input coupling transmits the power connecting input shaft.

7. Input shaft ass'y – (Fig. 2-1 F)

The input shaft is supported by the spherical bearing, ball bearing and needle bearing in the input shaft cover and assembled with the steel plates. While engaging on the clutch, the hydraulic pressure piston pushes the sintered and steel plates, which transmits the power into the output shaft. When the engine is running, the input shaft is always driving and the pump gear is shrink-fitted.

2-3 PUMP CONNECTOR GEAR – (Fig. 2-1 J)

It's power is increased at the certain ratio and transmitted with pump input gear inside the input shaft.

2-4 PUMP CONNECTOR SHAFT – (Fig. 2-1 H)

It is assembled inside the pump input gear and with pump driving block and it drives the hydraulic pump by "KEY"

2-5 OUTPUT SHAFT GROUP

Output shaft assembly is shrink-fitted with the cluster of output shaft and clutch housing which consists of hydraulic piston, sintered plates and steel plates inside. Both side shaft is supported with the spherical roller bearing and needle roller bearing.

Steel plates' inner teeth are inter locked with the gear of input shaft and turns as the same direction of the input gear. Sintered plates' outer teeth are assemble with the inner grooves of the clutch housing. The turning of input shaft makes steel plates turn and when the hydraulic pressure becomes the status of operation, the hydraulic piston pushes the sintered plates and steel plates and the power is transmitted. If the status of hydraulic pressure engages on the stop position, the power stops automatically by the return spring.

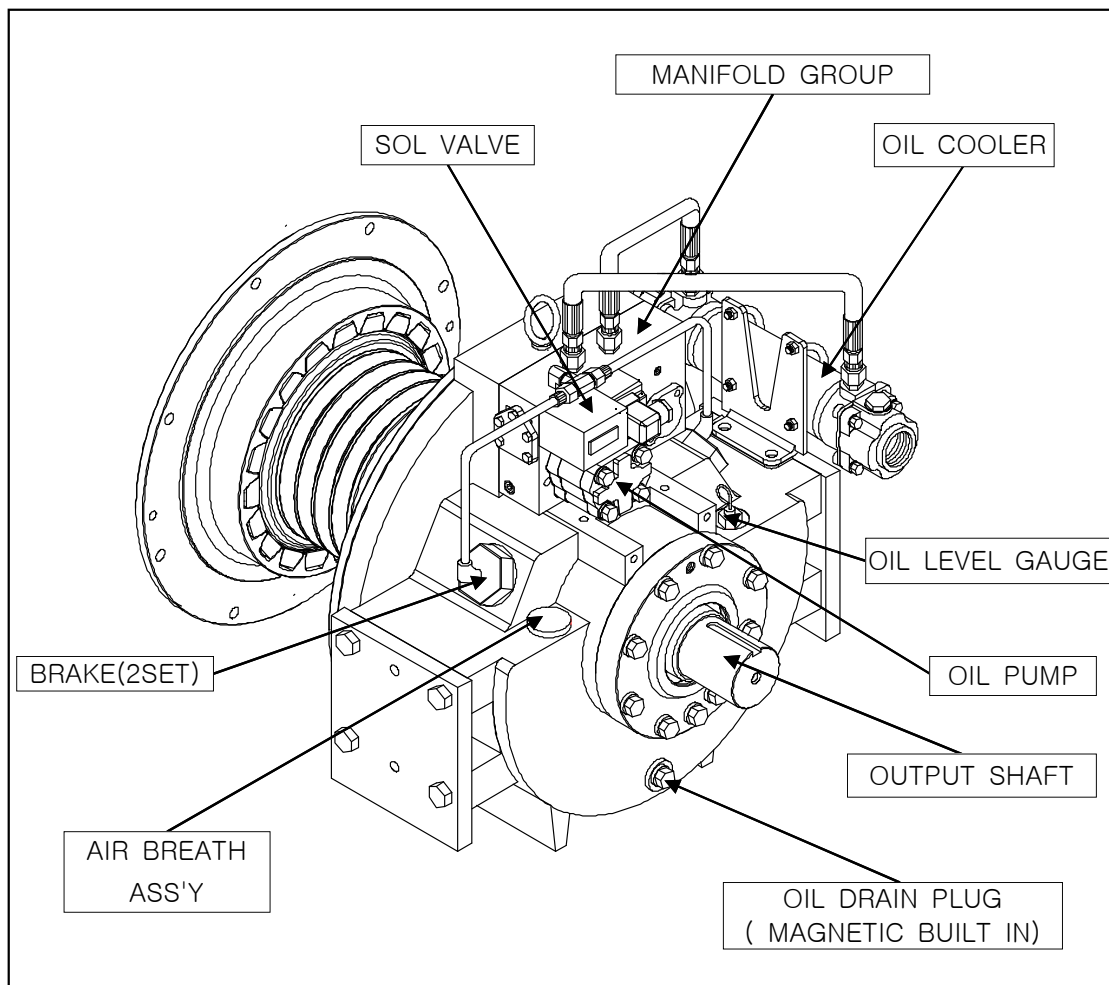

[FIG 2-2] PTO EXTERNAL STRUCTURE

2-6 CASE GROUP

The case group is made of cast iron and consists of the case and case cover.

2-7 MANIFOLD ASS'Y

Manifold is made of cast iron and consists of the pump and solenoid valve.

Oil path, which flows into and out the pump, is formed inside and the screen filter and filter ass'y are built inside.

2-8 SOL VALVE ASS'Y

Solenoid valve functions the operation and stop positions of the PTO by sign of electricity.

2-9 HYD' PUMP ASS'Y

The hydraulic pump is the circumscribed gear type, and assembled with one direction and reverse direction plates and bolted on the manifold. The pump driving gear is connected by a keyed way on the end of the pump connection shaft to be driven and rotated at the more increased speed than engine's and the rotation direction is opposite to the engine's one.

PERIODIC INSPECTION : REFER TO ANNEX I



In case of a special engine (clock wise seeing from rear of the engine), please contact with D-I for consultation.

2-10 BRAKE ASS'Y

Two(2) Brakes are installed on the left and right sides of the case. As the brakeshoe is assembled inside of the piston of brake plug and stucked closely in the clutch housing, it functions the stop when the clutch turns with the failure of stop. On the position of operation, the shoe stick is returned by brake spring and on the stop position, the brake operates by hydraulic pressure.

PERIODIC INSPECTION : REFER TO ANNEX I

2-11 SCREEN FILTER ASS'Y

The Screen Filter Assembly is connected with a suction pipe to the inlet side pump and is fixed by the screen filter cover on the bottom side of the manifold.

PERIODIC INSPECTION : REFER TO ANNEX I

2-12 OIL COOLER

The Oil Cooler is the device which cools the operating oil inside of PTO and uses the sea water as the cooling water. It is fixed above the case cover with bolts, and cools the oil supplied from the hydraulic pump and then sends the oil to the solenoid valve. The oil cooler contains albrass (mixed aluminum and brass) pipe which is resistant to corrosion. zinc anode are put into the both sides of the oil cooler.

PERIODIC INSPECTION : REFER TO ANNEX I

SECTION 3 – PRINCIPLES OF OPERATION

3-1 GENERAL

PTO(DPO-210/310) is operated by hydraulic pressure and must be operated within the limits of load capacity described on our catalogues or technical data.

It is designed with the same axle as engine and the rotation direction is the same as engine.

Since the clutch consists of hydraulic multiple plates, the operation of PTO is accomplished by hydraulic pressure.

Each component of PTO is force-lubricated or splash-lubricated.

Force-lubricated : Oil seal, Bearing, Brake, Plates, and etc.

Splash-lubricated : Pump input gear, Pinion gear.

3-2 ROTATION DIRECTION

The input shaft and output shaft is rotated in the same direction as engine.

3-3 POWER TRANSMISSION FLOW

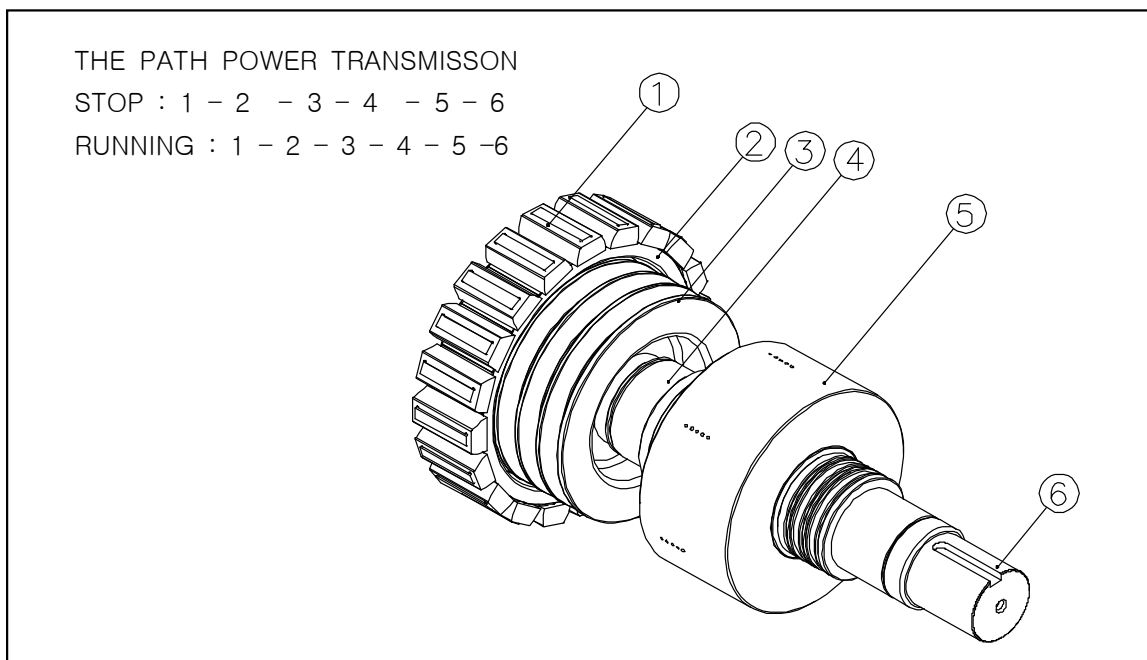

[FIG. 3-1] POWER TRANSMISSION FLOW

3-3-1. STOP POSITION

- ① Power is transmitted from a dummy plate, which is fitted to a pulley of a engine with bolts, to the spider(②) fitted with rubber blocks(①).
- ② The power is transmitted to input shaft(④) through the input coupling (③) of the PTO and then clutch housing(⑤) and the output shaft(⑥), which is shrink-fitted to the input shaft, rotates together.
- ③ The input shaft(④) fitted with the input coupling(③) rotates and the steel plates fitted with the input shaft rotates in the same direction as engine.

3-3-2. OPERATION

- ① Oil pressure which is regulated in solenoid valve pushes hydraulic pistons in the clutch.
- ② The steel and sintered plates in the clutch are stuck fast to each other and then rotate together.
- ③ The sintered plates are interlocked with internal gear of clutch housing (⑤)and the power is transmitted to output shaft(⑥) which is shrink-itted to the clutch housing.

3-4 OPERATING METHOD BY SOLENOID VALVE

The electrical signal by operation of control box activates solenoid valve on PTO main body, and it operates or stops the equipment.

(B-TYPE control box) (refer to FIG. 3-2)

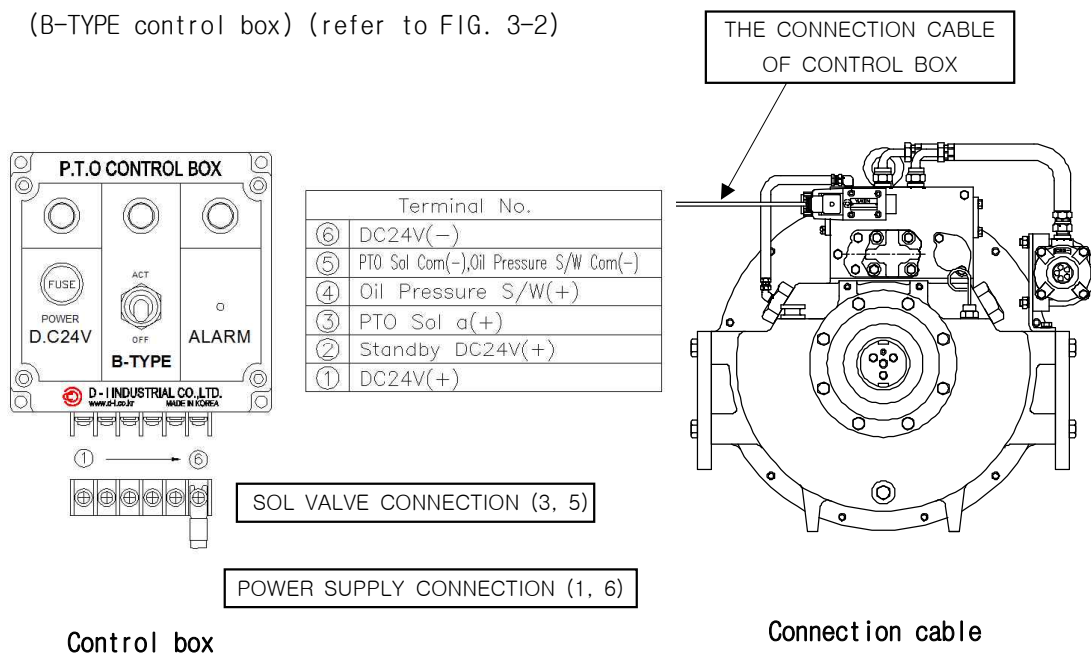

[FIG. 3-2] PTO main body/control box that solenoid valve is installed

SECTION 4 – HYDRAULIC SYSTEM

4-1 GENERAL

The hydraulic system is shown in [FIG. 4-1]. The oil contained in the PTO flows into the pump through the oil screen filter. High pressure oil discharged from the pump is led to the oil cooler and solenoid valve by the pressure regulating valve and regulated by the lubricating pressure valve and operating pressure valve and the oil is supplied to operate the clutch and to lubricate the each component.

According to the operating position of solenoid valve, the oil is supplied through the path of Stop and Operation position.

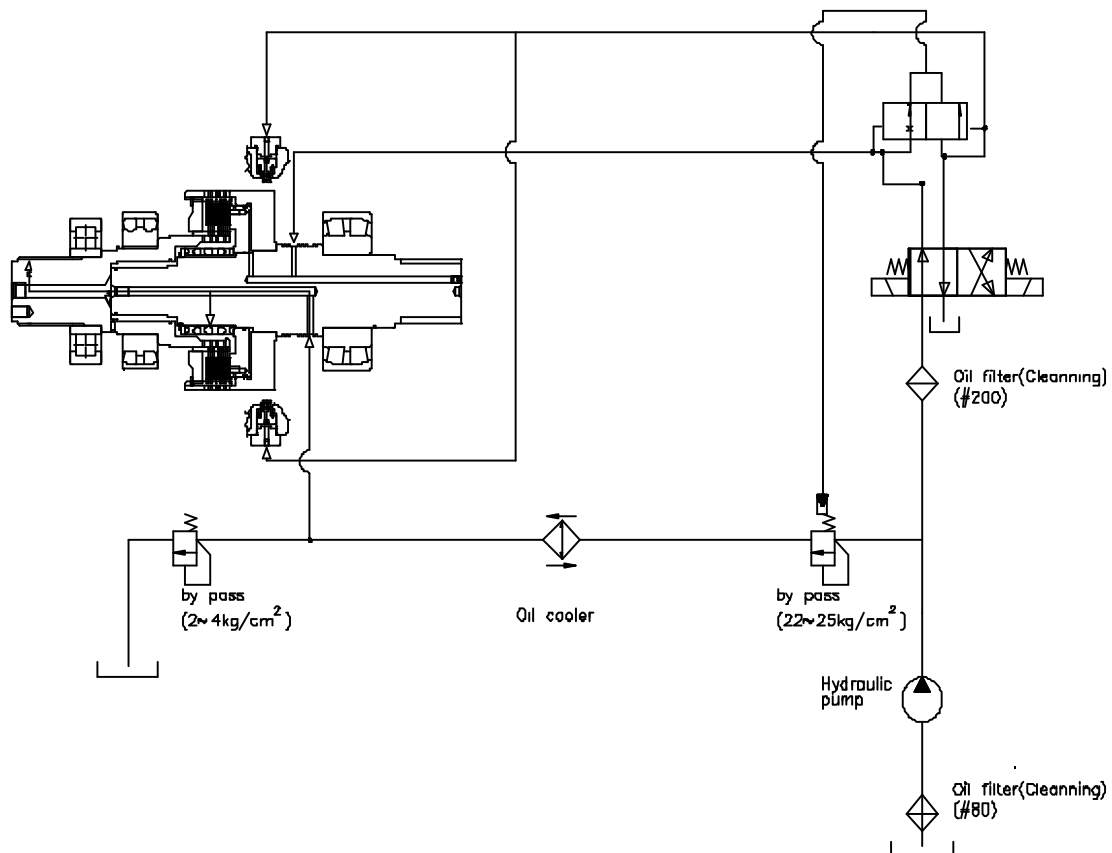

[FIG. 4-1] HYDRAULIC CIRCUIT DIAGRAM

4-2 MANIFOLD ASS'Y

1. The oil discharged from the pump is led into the inside P of the solenoid valve through the oil filter.
2. Oil flow direction on the solenoid location.

1) STOP POSITION [FIG. 4-2]

The oil fed in the "P" space maintains the pressure through the line of A-1 and the line of A-2 and moves into brake through the line A-3 and pushes the brake piston and stops the rotation of output shaft.

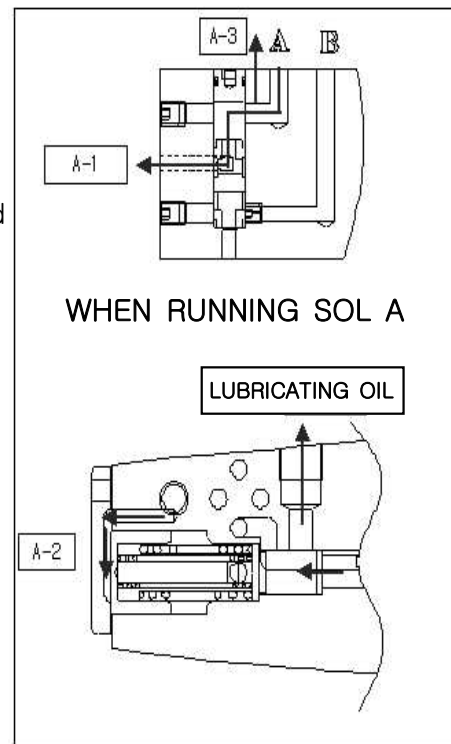

[FIG. 4-2] OIL FLOW WHEN STOP POSITION

2) ACTION (OPERATION) POSITION [FIG. 4-3]

The oil fed in the "P" space moves into A-1 and A-3 through the location "B". The oil of A-1 makes the operation delayed and maintain the regular pressure.

The oil of the regular pressure moves into A-3 through the output shaft and pushes the hydraulic piston of the clutch housing and makes the steel and sintered plates stuck adhered and then the steel plates and input shaft are in a body and make the output shaft rotated.

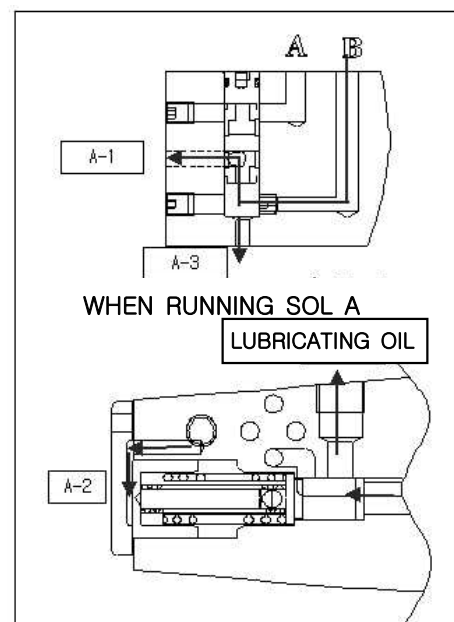

[FIG. 4-3] OIL FLOW WHEN ACT POSITION

SECTION 5 – INSTALLATION

Installation of PTO has an important effect on the function and performance of the PTO. Therefore, please study this manual before installing the PTO.

GAUGE/TOOL	SPEC	REMARK
DIAL GAUGE	0.01	
MAGNETIC BASE	-	
THICKNESS GAUGE	0.01 ~ 1	
SPANNER/WRENCHES	M16 ~ M32	



DANGER

MAKE SURE NOT TO RUN ENGINE WHILE INSTALLING PTO

5-1 IN CASE THE PTO IS COUPLED TO THE FRONT OF MARINE ENGINE

1. Installation (MUST REFER TO THE DRAWING ATTACHED FOR THE CONCENTRIC DEGREE AND VERTICAL ANGLE DEGREE OF PTO AND ENGINE)

1) Process and fitting of the dummy plate

- ① After check the diameter (A) of engine pulley and tapping, process the dummy plate as of the below figure.
- ② Fit the dummy plate by using the screws.

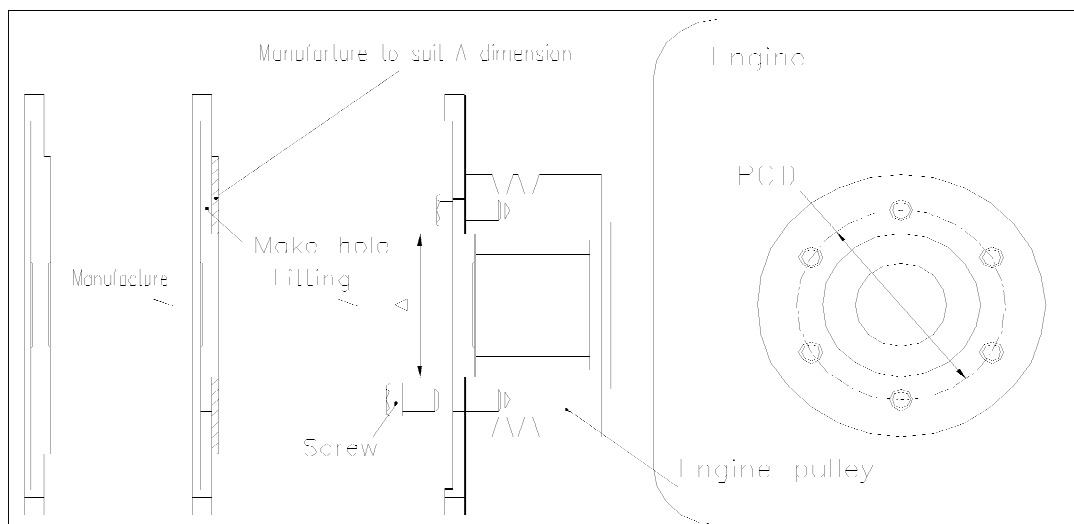

[FIG. 5-1] FITTING DUMMY PLATE

2) Inspection of the diameter of the dummy plate guide (Concentricity) [FIG.5-2.]

Install a dial test indicator gauge as shown [FIG. 5-2], and read off the deviation of indicator gauge's scale, by rotating the pulley in the same direction. At this point, the value of deviation should not exceed 0.2 mm.

3) Check the dummy plate face (Flatness) [FIG. 5-3].

Install a dial test indicator gauge as shown [FIG. 5-3], and read off the deviation of indicator gauge's scale, by rotating the pulley in the same direction. At this point, the value of deviation should not exceed 0.2 mm.

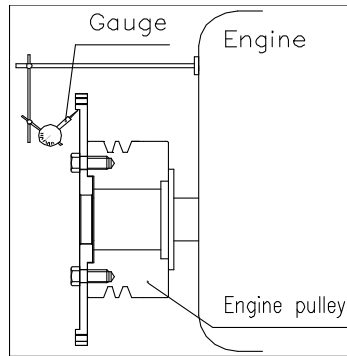

[FIG. 5-2] CONCENTRICITY

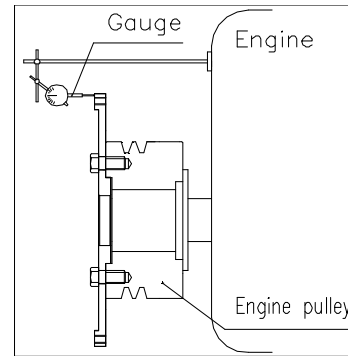

[FIG. 5-3] FLATNESS

4) Coupling PTO to Engine : The alignment of the engine and PTO is the most important factor for normal performance and extended life.

(1) Bedrail : Use the engine bedrail made of well-dried rigid wood or steel.

If the engine bedrail is not rigid, the alignment will deviate due to the vibration of the engine or other influence.

(2) Fitting PTO and Fixing

①Fit driving ring to the dummy plate with bolts.

②Fit the PTO rubber blocks assembled into the driving ring.

③After fitting, try to accord the driving ring and rubber blocks faces together(Refer to the detailed drawing of the back in this manual)

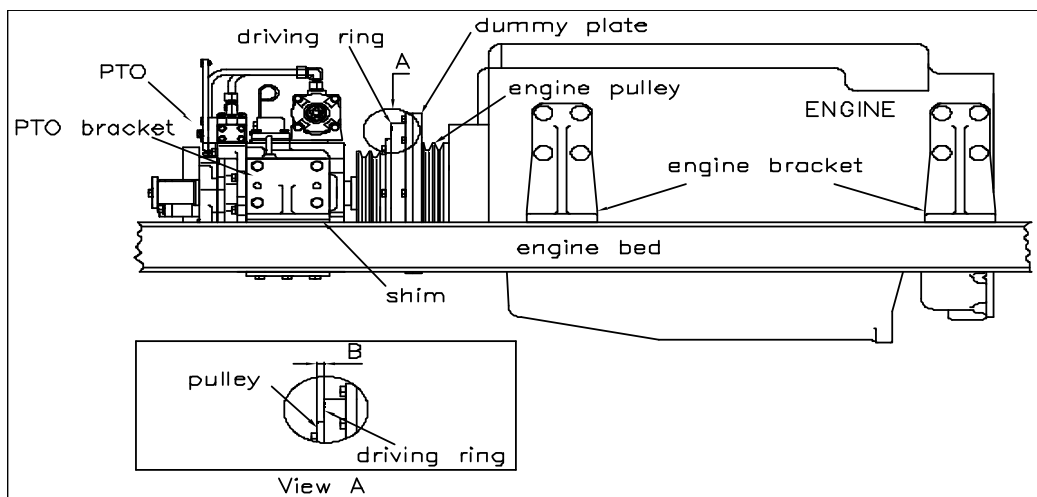

[FIG. 5-4] PTO installation



CAUTION

If the dummy plate and the brackets are not bolted firmly, they could be broken due to the vibration of engine while cruising.

5-2 IN CASE PTO IS COUPLED TO AUXILIARY ENGINE (Option)

1. Checking point before installation

Clean Engine flywheel and flywheel housing.

SAE HOUSING NO.	00	0	1/2	1	2	3	4	5	6
Flatness deviation	0.012	0.010	0.010	0.008	0.008	0.008	0.006	0.006	0.006
Concentricity deviation	0.012	0.010	0.010	0.008	0.008	0.008	0.006	0.006	0.006

[Table. 5-1]

- 1) Check the surface of the flywheel housing (flatness).

Install a dial test indicator gauge as shown in below figure, and read off the deviation of the indicator gauge's scale, by rotating the flywheel in the same direction. (Allowable deviation is referred to [table. 5-1])

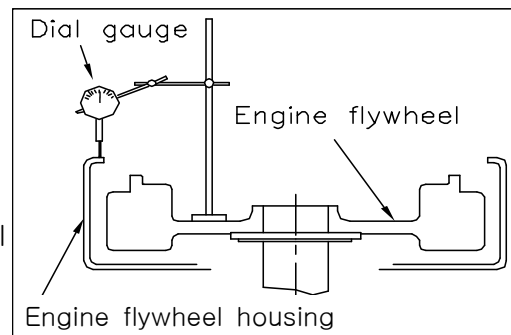

[FIG. 5-5] FLYWHELL HOUSING FLATNESS CHECKING

- 2) Check the engine flywheel housing guide (concentricity).

Install a dial test indicator gauge as shown in below figure, and read off the deviation of the indicator gauge's scale, by rotating the flywheel in the same direction. (Allowable deviation is referred to [table. 5-1])

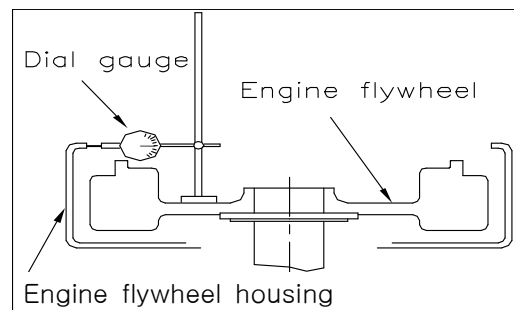

[FIG. 5-6] FLYWHEEL HOUSING CONCENTRICITY CHECKING

- 3) Check the surface of engine flywheel as shown in below figure, and read off the deviation of the indicator gauge's scale, by rotating the flywheel in the same direction. (Allowable deviation is referred to [table. 5-1])

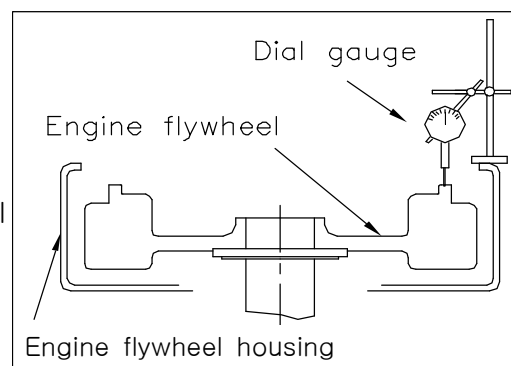

[FIG. 5-7] FLYWHEEL FLATNESS CHECKING

- 4) Check the diameter of the flywheel driving ring seating guide (concentricity)

Install a dial test indicator gauge as shown in below figure, and read off the deviation of the indicator gauge's scale, by rotating the flywheel in the same direction. (Allowable deviation is referred to [table. 5-8])

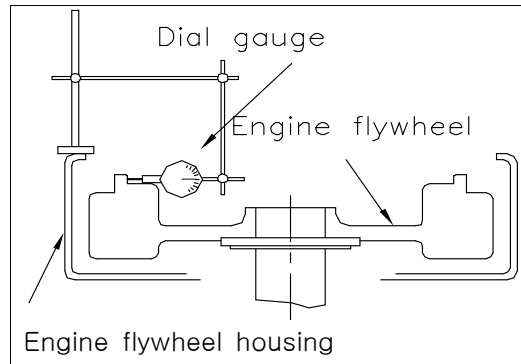

[FIG. 5-8] FLYWHEEL CONCENTRICITY CHECKING

2. Installation (REFER TO FIG. 5-9)

The alignment of the engine and the PTO is the most important factor for normal performance and extended life.

1) FIXING

The support brackets for the PTO have to be fixed to the engine bed firmly like the engine mounting.

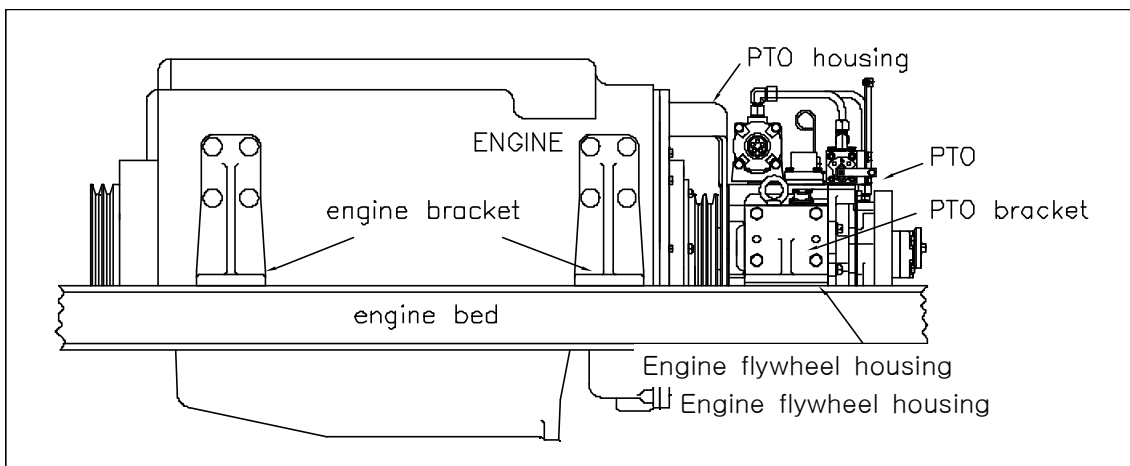

[FIG. 5-9] PTO INSTALLATION TO AUXILARY ENGINE

 CAUTION	<p>Bolts for housing and brackets of PTO should be tightened firmly. If not, a noisy, vibration or breakage of housing can occur while cruising.</p>
--	--

5-3 Installation of Control Box (B-TYPE)

1. Cautions of Installation

- * Do not install PTO in wet or watery spots.
- * Only DC 24V of power supply is allowed to be used.
- * Fix a control box and wiring firmly so that they do not move.
- * Be cautious when you fix the control box so that any short circuit does not occur.
- * Connecting and wiring should be conducted in the same method as shown in the wiring diagram. (refer to FIG. 5-12)

2. How to install

- 1) Select a place where PTO control is needed, and where you would fix the control box.
- 2) Connect cables to solenoid on PTO main body and terminal block correctly. When you connect the cables, make sure to check numbers and colors of them not to be confused. (refer to FIG. 5-10, TABLE. 5-2)

③ Blue	⑤ Brown
Sol a(+)	Sol a COM(-)

[TABLE. 5-2] The wire colors and numbers of solenoid

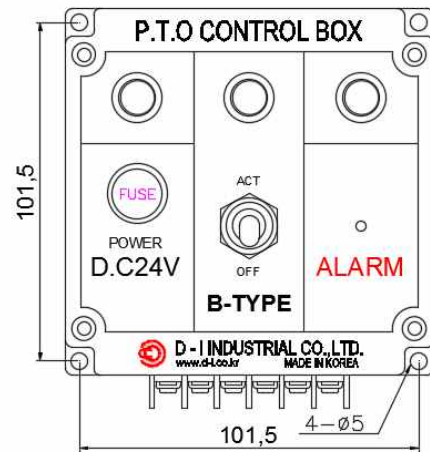

[FIG. 5-10] Installation of control box

- 3) Wire the electric cables connected to PTO main body to the spot where control box is placed and to the terminal block. Then mark the terminal block which is connected to the control box and the electric cables in order not to be confused when connecting them.
- 4) Control box should be fixed firmly. When you fix it, open the cover not to trigger any short circuit.
- 5) Before you connect the cables, all the switches should be placed at the positions as shown in the figure. (refer to FIG. 5-11, Table. 5-3)

Up	Down
ACT	OFF

[TABLE. 5-3] Switch operation

PTO operation switch OFF

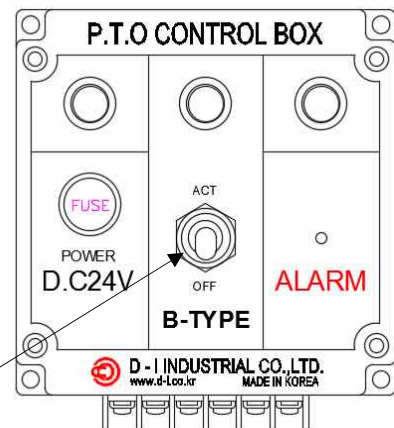

[FIG. 5-11] Switch position when installed

- 6) Connect the terminal block and wires which are connected to PTO main body

- to terminal block behind the control box using electric cables. (refer to FIG. 5-12)
- 7) Connect electric cables to power supply (DC 24V) so that power flows through them. +(red) should be connected to terminal no.1 and -(white) to terminal no.6. Terminal no.2 connects to none of the cables when installed since it will be used as standby power supply terminal when fuse has broken.
 - 8) The wiring connection should be conducted in the same method as shown in the figure. Otherwise, malfunctions might occur or even the machine would not be operated.

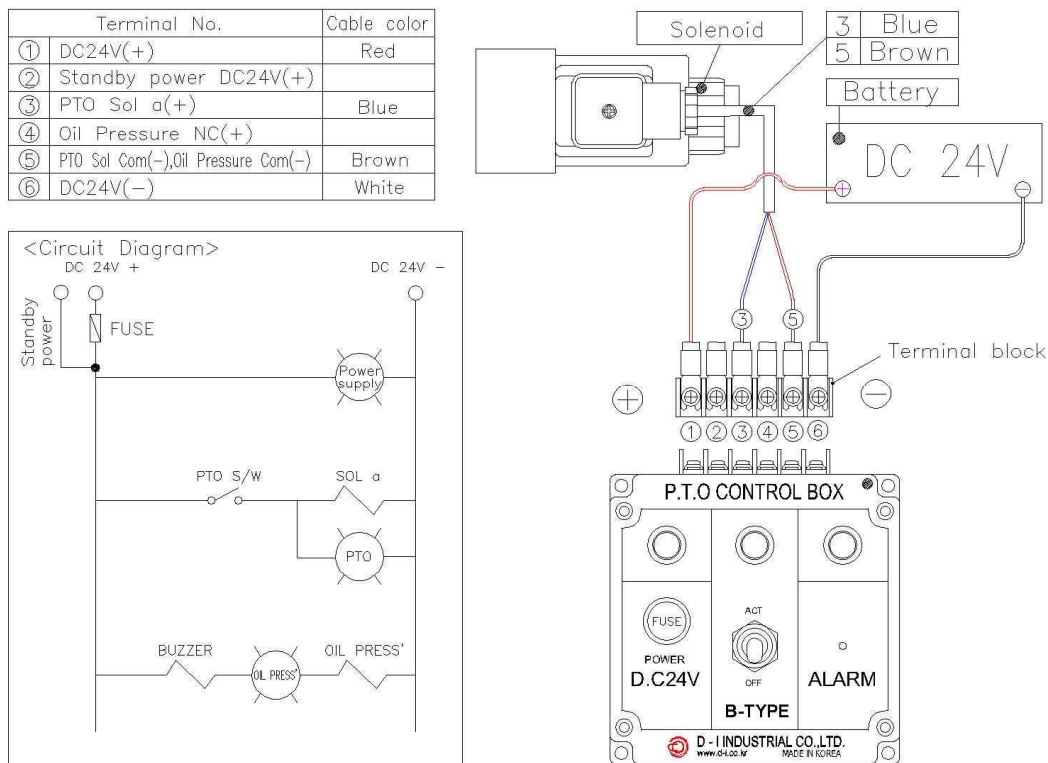

[FIG. 5-12] The wiring connection of control box and electrical circuit diagram

5-4 How to check the polarity of control box power supply (In case the polarity is unknown)

1. Cautions

- * Only terminal no.2 and 6 will be used to check the polarity, and all the connection of electric cables should be separated from the terminals.
- * When you connect wires, the switch should be placed at 'OFF' and the power should be blocked.

2. How to check the polarity

- 1) Connect two strands of power supply wire to terminal no.2 and 6. (Block the power supply while connecting them)
- 2) Energize the power after connecting power supply wires.
- 3) If power lamp is turned on, one strand connected to terminal no.2 is +(positive) and the other connected to terminal no.6 is -(negative).
- 4) Connect the +(positive) wire to terminal no.1, and -(negative) wire to terminal no.6
- 5) If the power lamp is not turned on when the power energizes control box, connect the wires the other way around and energize it again to check the power lamp.
- 6) If the power lamp is turned on, check the polarity and connect cables according to step 3 and 4.



DANGER

Do not install the control box in spots where sea water or rainwater comes in. Only DC 24V of power supply is allowed to be used.

SECTION 6 – OPERATION

6-1 PREPARATIONS FOR OPERATION

1. Check all the parts of PTO, and check if bolts, nuts, etc in major parts are tight.
2. Check the oil level with oil level gauge.
(Run the engine at idle speed for a few minutes, and check immediately after stopping it)
3. Place the operating switch of control box on the Stop position before starting the engine

**CAUTION**

Check the oil of PTO before operation.
If the oil is insufficient, fill to correct level.

6-2 OPERATION

1. Run the engine at idling speed for about 10 minutes for warming-up.
2. At this point, check oil leakage, abnormal noise, overheating, coolant condition, etc.

6-3 OPERATION AND STOP

1. The normal temperature of oil in the PTO during continuous actuation is between 50–90°C, but may be raised a little due to frequent Operating, Stand-by and Stop operation.
2. Check at all the time if there is abnormal noise or over-heat during operation. If an abnormal condition is found, stop the engine, find out the cause and correct it.
3. Shift the lever of PTO to the Stop position before stopping the engine.

**CAUTION**

Before operation of PTO, ensure engine RPM is suitable to run the other equipments fitted to the PTO

6-4 How to operate control box (B-TYPE)

1. Checks points before operation

- * The power lamp should be turned on when the power is connected to control box. Check the power connection part and battery if the lamp is not turned on.
- * PTO main body and cables of control box should be connected.
- * Operation switch of control box should be placed at 'OFF' when engine starts.
- * Check the connection and wiring system referring to the wiring diagram.

2. Operation method

- 1) Place the operation switch of control box at 'OFF' when engine starts.
- 2) When the power is connected, the red lamp above fuse will be turned on.
- 3) When you place the switch at 'ACT', the green lamp will be turned on, the power will energize the solenoid on PTO main body, 'Sol a' will be activated, and the lamp on solenoid will be turned on.
- 4) Conduct the opposite sequence of operation method if you shall turn off the power. (Operation switch at 'OFF' → Block the input power)

3. Cautions

- * If control box does not operate in spite of the same wiring system as the circuit diagram, open the fuse cap and check the fuse inside of control box.
- * If the fuse inside of control box has broken, connect the cable in terminal block no.1 to terminal block no.2, which is standby DC24V(+).
- * Replace the broken fuse after using standby power supply, and reconnect the standby DC24V(+) cable in terminal block no.2 to terminal block no.1.
- * The fuse will be broken when current over 3A flows through the control box. In this case, find and solve the cause of overcurrent and replace the fuse.
- * PTO should be turned off when it is not used. Otherwise, it might be dangerous due to sudden operation of the equipment when engine starts, and the solenoid valve could be broken due to overheat.
- * In case the lamp on the solenoid valve is not turned on when you activate the switch of control box, follow the emergency manipulation steps below.
(refer to FIG 6-1)

- 1) Remove snap pins fixed on emergency knob at the tip of solenoid.
- 2) Push in the emergency knob fully by turning it clockwise. (about 5mm)
- 3) Emergency manipulation mode should be cleared when it is not used. Release the emergency knob and fix it with snap pins.

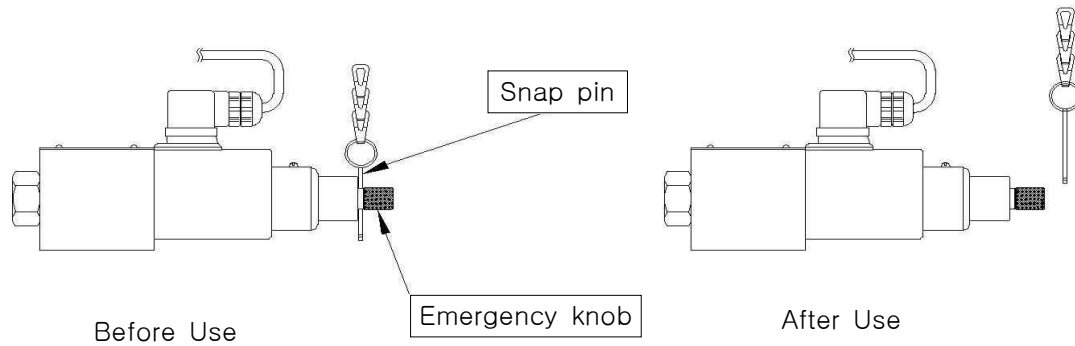

[FIG. 6-1] Solenoid in PTO main body



DANGER

It could be dangerous when you control PTO manually due to operation of other machinery. Make sure that operating valve of equipment is locked before manipulation.

SECTION 7 – PREVENTIVE MAINTENANCE

7-1 GENERAL

All the rotating parts in the PTO is lubricated by oil in the PTO. Followings are the check points for maintenance of the proper performance.

7-2 OIL

1. Use only SAE-API service class SAE#30 engine oil.

 CAUTION	<p>Use only SAE-API service class SAE#30 engine oil. Multi-grade oils (SAE#10W, 15W40, etc) should not be used in D-I PTO because they have influence on the coefficient of friction and cause the clutch to slip.</p>
--	--

2. Check the oil level every day.
3. Replace the oil after first 100hours operation and then every 1000hours.

 CAUTION	<p>If a foreign substance such as clean water, seawater, etc has come into the PTO, overhaul and clean all parts before assembly. Refill with new oil.</p>
--	--

7-3 OIL FILTER

At the time of oil replacing, clean screen filter and magnetic plug.

7-4 VISUAL INSPECTION

Inspect the external parts of PTO frequently and repair if any defect is found. Particularly, inspect the rubber blocks and replace them with new ones if they are damaged or worn out.

7-5 OVERHAUL

1. Look for our distributor in your country for overhaul of the PTO or our head office
2. Replace all gaskets, o-rings, and other rubber products in every overhaul.
3. Replace rubber blocks and bearings after 10,000hours operation or earlier if excessive wear or damage is found.

SECTION 8 – TROUBLE SHOOTING

If something is wrong with the PTO, refer to [Table. 8-1]

[Table. 8-1]

Symptom	Cause	Remedy
Low main oil pressure	Oil strainer clogged	Remove the residue and clean
	Oil pressure regulating valve stuck in the control valve	Remove the residue and clean
	Seal damaged or worn	Replacement
	Hydraulic pump damaged or worn	Replacement
	Clutch oil pressure regulator valve's spring damaged or worn	Inspect length of spring and replace it if necessary
No oil pressure	Oil level low	In case of oil leakage, replace of the components such as gaskets, oil seals, etc. which cause oil leakage and fill the oil
High main oil pressure	regulator pressure valve operated poorly	Remove the residue and clean
Low Lubricating oil pressure	Lubricating oil pressure regulating valve operated poorly	Remove the residue and clean
Over-heat	Clutches slipping	Disassemble PTO and check the clutch plates
	Excessive oil level	Regulation of oil level
	Bearing damaged	Overhaul PTO and check the bearing.
Rotating parts defective	Clutch plates stuck	Disassemble of clutch ass'y and replace clutch plates
	Pinion bush stuck	Disassemble and replace
	Clutch piston's returning spring is damaged or broken	Disassemble and replace of spring
Improper Shifting	Clutch plates stuck	Disassemble of clutch ass'y and replace clutch plates
	Defective Remote controller	Adjust and replace the remote controller
	Clutch piston's return spring is damaged or broken	Disassemble and replace the spring
Abnormal noise	Gear teeth or spline damaged worn	Disassemble and repair or replace
	Bearing damaged	Disassemble and replace
	Rubber blocks damaged or worn	Disassemble and replace
	Bolts or nuts loosened or removed	Secure tightening

ANNEX I (PERIODIC INSPECTION TABLE)

○ Check, ⊙ Exchange

	NAME	Check / Exchange (year)				Parts to Using	Remark
		1	3	5	10		
P T O B O D Y	*Gasekt, paper				⊙	Case, Manifold, Input / Output shaft cover etc.	
	*Gasekt, copper				⊙	Drain & Magnet Plug etc.	
	*O-Ring				⊙	Screen Filter, Clutch etc.	
	*Seal, oil				⊙	Input / Output Shaft	
	Ring, oil Seal		○		⊙	Output Shaft	Wear, Breakage
	Spring		○		⊙	Brake	
	Brake Shoe		○	○	⊙	Brake	Wear, Breakage
	Plate (sintered/steel)		○	○	⊙	Clutch housing	Wear, Taken off, Transformed
	*Snap Ring				⊙	Input / Output Shaft	
	Trust Metal			○	⊙	Pulley Shaft	Wear, Damage, Taken off
	Needle Bearing			○	⊙	Input / Output Shaft	"
	Bearing, spherical roller			○	⊙	Output Shaft	"
	Bearing, roller			○	⊙	Input shaft cover	"
	Bearing, ball			○	⊙	Pump, Input & Output Shaft	"
	※Magnet Plug						
	※Oil(SAE#30)						Refer to Section 7-2
	※Screen Filter		⊙	⊙	⊙		Breakage, Transformed
P U M P	*Gaskets					BODY, pump	
	Bush Bearing			○		Pump Gears	Wear, Damage, Taken off
	Pump Ass'y			⊙	⊙		
C O O L E R	*Gasket, paper					Oil cooler cover	
	*Gasket, copper					Bolt, union	
	Zinc Anode						Every 6 month to exchange

★ **MARK** : The parts, which are marked *, should be replaced with new ones once marine transmission is disassembled and assembled.

※**MARK** : The parts, which are marked ※, are recommended to be cleaned when replacing oil (Replace oil after first 100hours and then every 1000hours)

★When you need to repair after 3, 5 and 10 years, please contact A/S department in Head office.

ANNEX II
PARTS ORDER SHEET

Fill out the blanks below and get in touch with distributor							DATE	
COMPANY								
NAME								
ADDRESS								
TEL.		FAX.						
PARTS ORDER LIST								
MODEL				Gear Ratio				
				Serial No.				
ENGINE		HP/	rpm	Installation date				
PTO Left use				PTO Right use				
No.	NAME	PARTS NO.	Q.TY	No.	NAME	PARTS NO.	Q.TY	
REMARK								

ANNEX III

WARRANTY LETTER

The PTO, which D-I Industrial Co., Ltd manufactures, is guaranteed to have a good operation in case that D-I PTO is operated according to the instructions mentioned in the D-I PTO manuals. D-I industrial Co.,Ltd warrants D-I PTO as follows.

1. SCOPE OF WARRANTY

Warranty is limited to repair or supply with new one against D-I PTO or its parts which is occurred by defective materials or workmanship within warranty period.

2. WARRANTY PERIOD

D-I Industrial Co., Ltd warrants against defective materials or workmanship for a period of twenty-four(24) months from the date of original shipment by D-I Industrial Co., Ltd. to original customer or twelve(12) months from the first sea trial, whichever occurs first.

3. WARRANTY NON EFFECTIVE (D-I Industrial Co.,Ltd dose not warrant.)

- 1) The parts that are not produced by D-I Industrial Co., Ltd. or genuine parts which are lost.
- 2) The cost or the breakdown that occurs for repairing before contacting with D-I Industrial Co.,Ltd.
- 3) The breakdown which is occurred due to any modification to D-I PTO or its parts without the prior consent of D-I Industrial Co.,Ltd.
- 4) The breakdown that is occurred due to the customer's negligence, faulty maintenance. Misuse or non observance of recommended or operation instructions.
- 5) Consumable parts such as Gaskets, packings, tubes, and etc.,

4. OBLIGATION OF USERS.

- 1) D-I PTO should be inspected and repaired according to the instructions mentioned in the manuals.
- 2) Use of unsuitable parts, inspection or repair can cause a fatal damage. In case that D-I PTO should be repaired in a workshop, use a workshop that is appointed by D-I Industrial Co.,Ltd.

5. WARRANTY REPAIR

- 1) This warranty letter is accompanied D-I PTO and is effective with signature of D-I Industrial Co.,Ltd.
- 2) Users should submit this warranty letter to warranty repairman when warranty repair or periodic inspection.

6. D-I Industrial Co.,Ltd. does have no obligation to apply new specifications to the D-I PTO that was supplied before changing specifications.

7. WARRANTY SUCCESSION

In case that owner is changed because D-I PTO is resold or contributed to the other customer within warranty period, D-I Industrial Co.,Ltd warrants the rest of warranty period. In order to do that, this warranty letter should be accompanied with D-I PTO.

D-I INDUSTRIAL CO.,LTD.

The contents of this manual can be modified without prior notice for the improvement of quality.



FACTORY : (52781) 13, Namgang-ro
1367 beon-gil, Jinju-si,
Gyeongnam-do, Korea
TEL. : +82-55-760-5500
FAX. : +82-55-755-9188
E-mail : dicl@d-i.co.kr
URL : <http://www.d-i.co.kr>

MAMU NO. M1902N01DPO



printed: 2019. 00