

MARINE TRANSMISSION

DMT110A

■ Standard Scope Of Supply

- Bell Housing (SAE 1, 2, 3)
- Dual Stage Coupling(14" 11.5")
- Propeller Coupling, Reamer Bolt
- Manual Control Valve
- Oil Cooler
- Cable Bracket

■ Options

- Manual Trolling Valve
- Electronic Control Valve(12V,24V)
- Manual Trolling Valve + Electronic Control Valve(12V, 24V)
- Mounting Bracket (Flat type, L type)

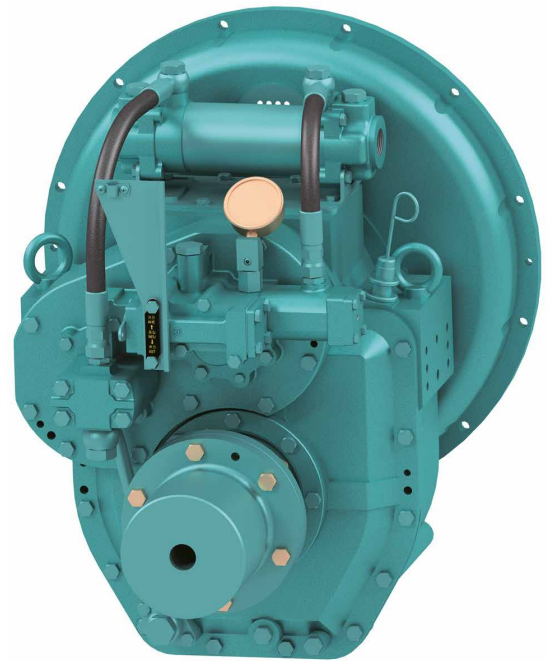

Model	Ratio	Max Input Torque		Capacity/RPM		Capacity/1800RPM		Max Input (RPM)	Bell Housing (SAE)	DRY WEIGHT (kg)
		(kgf.m)	(N.m)	kW	HP	kW	HP			
DMT110A	1.77*, 2.09, 2.42, 2.82, 3.19, 3.81	110	1079	0.112	0.151	202	272	2800	1, 2, 3	179

*Special Order Ratio

※ The dry weight is the weight that excludes bell housing, coupling (rubber block, dual stage, Centa flexible) and propeller coupling from the standard scope of supply.

※ The capacity for classification may differ from the capacity on the table, please contact our sales team.

DMT110A Dimensions

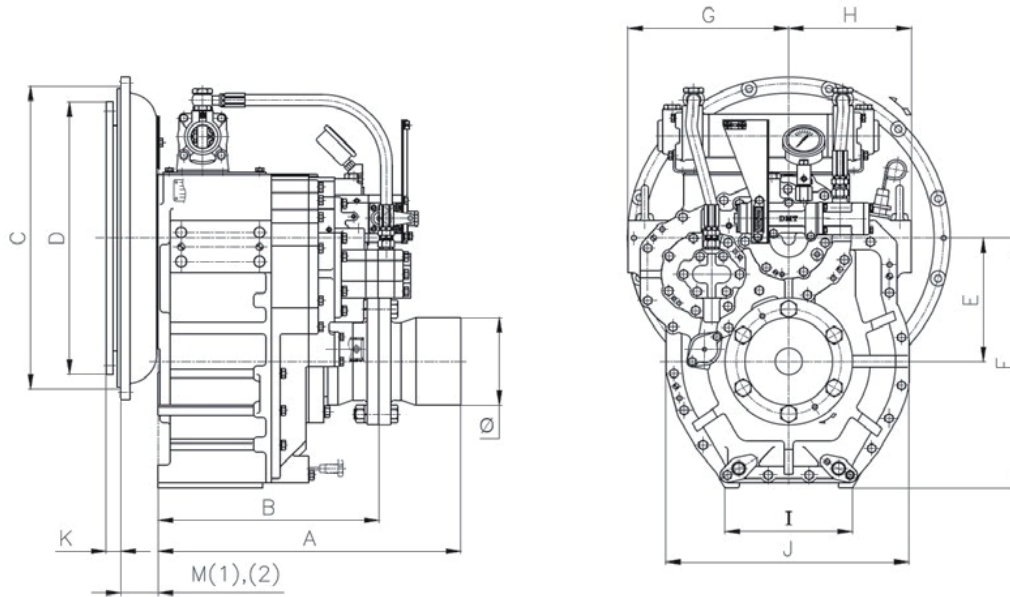

A	B	E	F	G	H	I	J	Ø
487	335	195	388	249	197	224	386	140

mm

Bell Housing Standard	Driving Ring	C	D	M(1)	M(2)	K
SAE#1	14"	511	466	75	-	25
SAE#2	11.5"	447	325	35	-	39
SAE#3	11.5"	409	325	35	-	39

mm

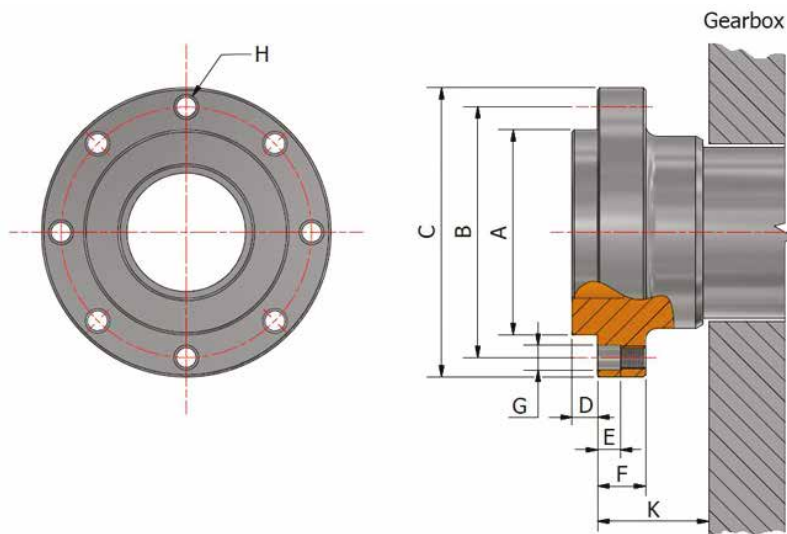

A	B	C	D	E	F	G	H	K	
Ø75	$\begin{matrix} 0 \\ -0.02 \end{matrix}$	Ø100	Ø117	4	10	20	Ø10.9	6-M10 P1.25	30.1

mm