

MARINE TRANSMISSION

DMT600BL

■ Standard Scope Of Supply

- Bell Housing (SAE 0)
- Centa Flexible Coupling (18")
- Propeller Coupling, Reamer Bolt
- Manual Control Valve
- Oil Cooler
- Cable Bracket

■ Options

- Manual Trolling Valve
- Electronic Control Valve(12V, 24V)
- Manual Trolling Valve +
Electronic Control Valve(12V, 24V)
- Mounting Bracket (Flat type, L type)

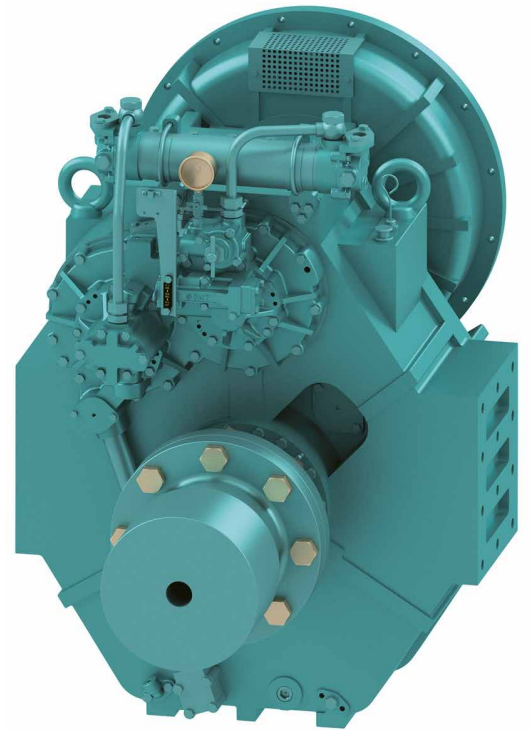

Model	Ratio	Max Input Torque		Capacity/RPM		Capacity/1800RPM		Max Input (RPM)	Bell Housing (SAE)	DRY WEIGHT (kg)
		(kgf.m)	(N.m)	kW	HP	kW	HP			
DMT600BL	4.12, 4.48	625	6131	0.641	0.860	1155	1549	2300	0	1489
	5.11	587	5758	0.602	0.808	1085	1455	2300		
	5.62	545	5346	0.559	0.750	1007	1350	2300		
	5.91	499	4895	0.512	0.686	922	1237	2300		

*Special Order Ratio

※ The dry weight is the weight that excludes bell housing, coupling (rubber block, dual stage, Centa flexible) and propeller coupling from the standard scope of supply.

※ The capacity for classification may differ from the capacity on the table, please contact our sales team.

DMT600BL Dimensions

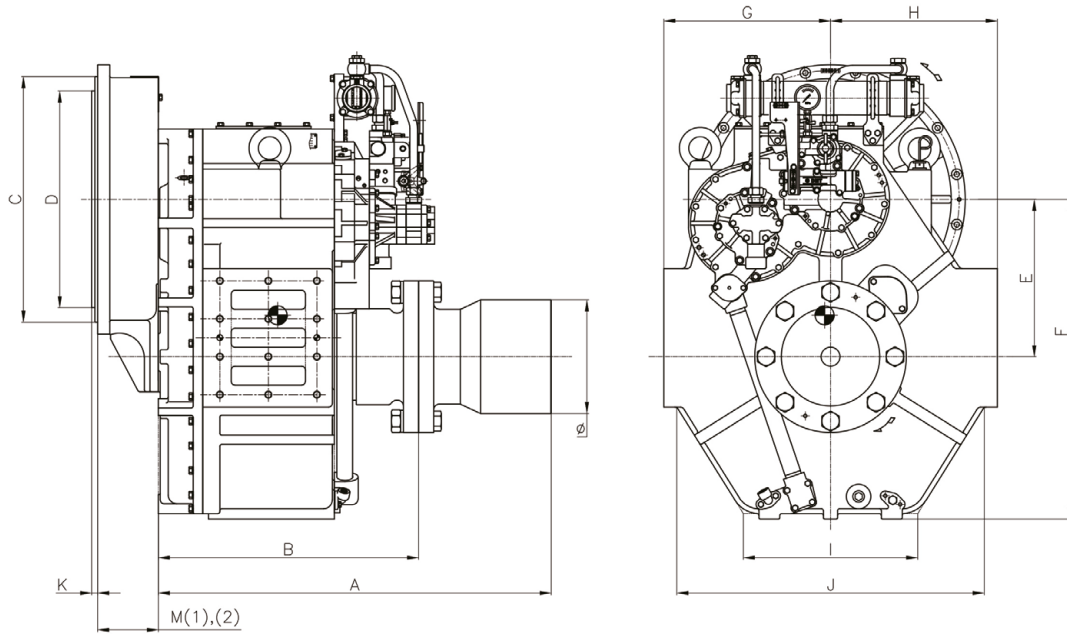

									mm
A	B	E	F	G	H	I	J	Ø	
1197	687	415	844	440	440	460	811	245	

							mm
Bell Housing Standard	Driving Ring	C	D	M(1)	M(2)	K	
SAE #0	18"	647	571	-	160	15	

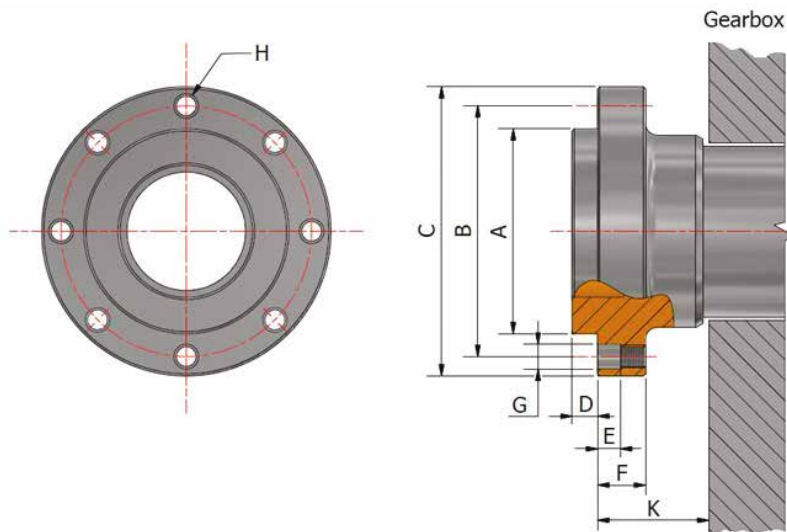

										mm
A	B	C	D	E	F	G	H	K		
Ø129	$\begin{matrix} 0 \\ -0.02 \end{matrix}$	Ø165	Ø187	47.8	11	25	Ø16	8-M14 P1.5		37.5