

MARINE TRANSMISSION

DMT90A

■ Standard Scope Of Supply

- Bell Housing (SAE 1, 2, 3, 4)
- Rubber Block Coupling (10")
- Dual Stage Coupling(14" 11.5")
- Propeller Coupling, Reamer Bolt
- Manual Control Valve
- Oil Cooler
- Cable Bracket

■ Options

- Manual Trolling Valve
- Electronic Control Valve(12V,24V)
- Manual Trolling Valve + Electronic Control Valve(12V,24V)
- Mounting Bracket (Flat type, L type)

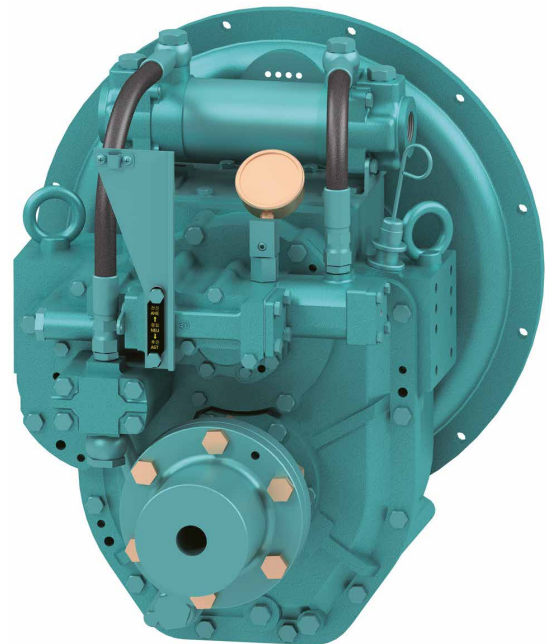

Model	Ratio	Max Input Torque		Capacity/RPM		Capacity/1800RPM		Max Input (RPM)	Bell Housing (SAE)	DRY WEIGHT (kg)
		(kgf.m)	(N.m)	kW	HP	kW	HP			
DMT90A	1.61*, 2.06, 2.45, 2.82, 3.12, 3.46	87	857	0.089	0.12	161	216	3000	1, 2, 3, 4	135

*Special Order Ratio

※ The dry weight is the weight that excludes bell housing, coupling (rubber block, dual stage, Centa flexible) and propeller coupling from the standard scope of supply.

※ The capacity for classification may differ from the capacity on the table, please contact our sales team.

DMT90A Dimensions

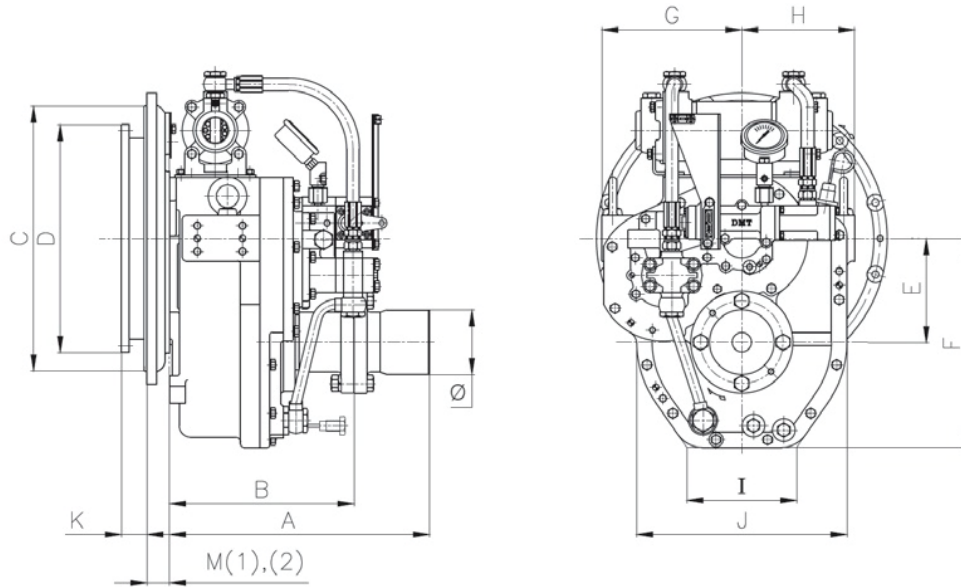

A	B	E	F	G	H	I	J	Ø
471	325	160	323	228	175	170	326	120

mm

Bell Housing Standard	Driving Ring	C	D	M(1)	M(2)	K
SAE#1	14"	511	466	75	-	25
SAE#2	11.5"	447	325	35	-	39
SAE#3	11.5"	409	325	35	-	39
SAE#4	10"	361	314	50	-	53

mm

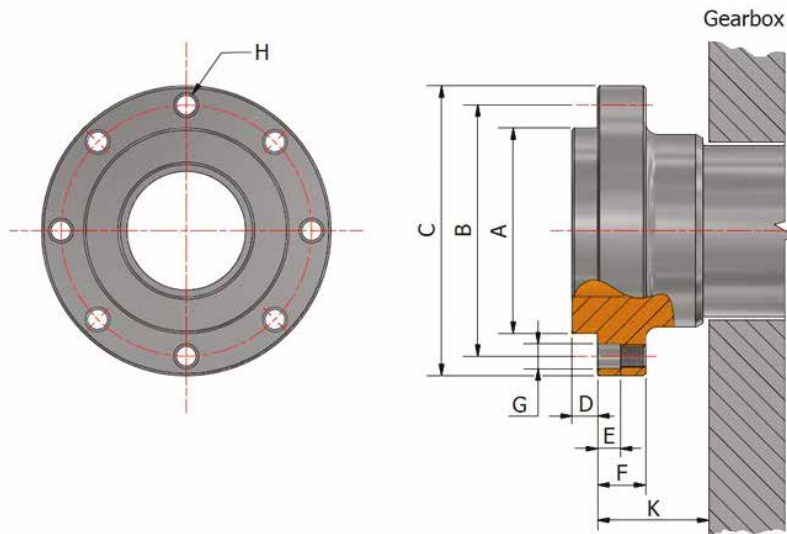

A	B	C	D	E	F	G	H	K	
Ø75	$\begin{matrix} 0 \\ -0.02 \end{matrix}$	Ø100	Ø118	5	10	20	Ø10.9	6-M10 P1.25	29.9

mm